

XCTouchNav Android Navigator Family

User Manual

80mm



5.7 Inch V2



7 Inch V3



Manual edition 1.20

info@xcvario.com

Table of Content

| | |
|--|----|
| Page 3- | 1 |
| 1. Description | 4 |
| 1.1. XCTouchNav Overview | 4 |
| Key Features: | 4 |
| Conclusion: | 5 |
| 2. Features | 6 |
| Design and Build | 6 |
| Performance and Display | 6 |
| Connectivity | 6 |
| Audio and Power | 6 |
| Thermal Management | 6 |
| Software and Features | 7 |
| 3. Overview | 8 |
| 3.1. XCTouchNav Integration in the Cockpit Environment | 8 |
| 4. Operation | 9 |
| 4.1. Local Flight | 9 |
| 4.1.1 Prior to Takeoff | 9 |
| 4.1.2 In Flight | 9 |
| 4.1.3 After Landing | 9 |
| 5. XCSoar | 10 |
| 5.1. Enhancing the Glider Flight Computer | 10 |
| 5.2. Advantages Over Consumer Devices | 10 |
| 5.3. Autostart of XCSoar (or other App) | 10 |
| 6. Advanced Features and Technology | 12 |
| Affordable and Reliable Solution | 12 |
| 7. Bluetooth | 13 |
| 7.1. Pairing the Device | 13 |
| Configuring XCSoar for Bluetooth Connection | 13 |
| Verifying the Connection | 13 |
| Additional Notes | 13 |
| 8. Wireless LAN | 13 |
| 8.1. Enable Wireless LAN on the XCTouchNav | 13 |
| Connect to the WiFi Network | 14 |
| Secure the Connection | 14 |
| Final Steps | 14 |
| 9. Installation | 15 |
| 9.1. 5.7-Inch Model | 16 |
| 9.2. 7 Inch V3: | 17 |
| 9.3. 80 mm: | 18 |
| 9.4. Electrical connections rear | 19 |
| 9.4.1. 5.7-Inch | 19 |
| 9.4.2. 7 Inch V3 Models | 19 |
| 9.4.3. 80mm Model | 20 |
| 9.5. 12V DC Power | 21 |
| 9.5.1. Power Supply Connection | 21 |
| Built-in Protections | 21 |
| Included Power Cable | 21 |
| Power Switch Considerations | 21 |
| 9.6. USB | 22 |
| 9.7. Audio Out | 22 |
| 9.7.1. Audio Output | 22 |
| Use Case | 22 |

| | |
|---|----|
| 9.8. RJ45 connector's ttyS3, ttyS4, etc..... | 23 |
| 9.8.1. IGC Standard Interface..... | 23 |
| 9.8.2. Power Supply..... | 23 |
| 9.8.3. Power Splitting:..... | 23 |
| Conclusion..... | 23 |
| 9.8.4. FLARM Connection and Power Supply..... | 24 |
| 9.9. KRT2 / ATR 833 / Becker Radio..... | 25 |
| 9.9.1. Radio Connection Setup for XCTouchNav..... | 25 |
| 9.9.2. Connection Steps for KRT2 Radio..... | 25 |
| 9.9.3. Connection Setup for ATR833 Radio..... | 25 |
| Summary..... | 25 |
| 9.9.4. Connection Setup for Becker Radio..... | 26 |
| 9.10. XCVario Setup..... | 27 |
| 10. Technical specifications..... | 28 |
| 11. Maintenance..... | 29 |
| 12. Warranty Policy..... | 29 |
| 13. Permit..... | 30 |
| 14. Limitation of Liability..... | 31 |
| 15. CE Declaration of Conformity..... | 32 |

1. Description

1.1. XCTouchNav Overview

The **XCTouchNav** family is a cutting-edge navigation system built on the **Android operating system**, offering exceptional flexibility with both **wired serial connections** and **wireless interfaces** such as **Bluetooth** and **WiFi**. This versatile device supports a wide range of popular Android applications, including **XCSoar**, **LK8000**, **Enroute**, **SeeYou**, and many others, providing a seamless experience for glider pilots.

Key Features:

1. **High-Resolution Display:**

- The **XCTouchNav** is equipped with a **sunlight-readable IPS display**, offering excellent visibility from almost any angle, even in bright sunlight. Despite its impressive brightness, the display maintains **low power consumption**, ensuring prolonged use without draining the battery.

2. **Device Variants:**

- The product line includes models designed to fit **standard 80mm panel cutouts** and larger versions with **5.7 or 7-inch displays**, catering to different cockpit configurations and pilot preferences.

3. **Connectivity Options:**

- The **XCTouchNav** supports triple connectivity by **wired serial connections and wireless interfaces Bluetooth and WiFi**, all at the same time, making it highly compatible with a wide range of external devices, including **FLARM** and **NMEA (GPS)** sources. This allows the device to seamlessly integrate with existing flight systems.

4. **XCSoar Integration:**

- The **XCTouchNav** comes preloaded with **XCSoar**, a powerful software solution tailored specifically for gliding. With an extensive library of glider polars, **XCSoar** can be customized for nearly any glider type. As the **XCSoar source code** is open-source and available on GitHub, developers can modify and enhance the software, introducing new features and innovations.

5. **Advanced Flight Features:**

- When paired with a **variometer system**, such as the **XCVario**, the **XCTouchNav** unlocks additional advanced features:
 - **True Airspeed (TAS)** calculations using **outside air temperature (OAT)** and a high-precision altimeter.
 - **Final glide calculations** using **TE vario signals** for highly reliable performance.
 - **Wind calculations** based on **GPS data**, providing accurate estimates for circling and zigzag wind patterns, which is particularly beneficial in flatland conditions.

6. **User-Friendly Touch Interface:**

- The **XCTouchNav** features an intuitive **touchscreen interface**, making it easy to operate **XCSoar** and other applications. Unlike devices that rely on complex rotary knobs, the touch interface provides a streamlined, user-friendly experience. The **anti-glare** and **anti-fingerprint screen** ensures clear visibility without additional protection.

7. **Extensibility and Compatibility:**

- The XCTouchNav is designed to integrate seamlessly with **FLARM devices, smart variometers,** and other compatible flight instruments. It offers a robust array of **wired and wireless connectivity options,** ensuring flexibility and extensibility for future upgrades or system integrations.

8. **High performance CPU**

- **Quad-core 1.8 GHz** CPU for best performance with low power consumption

9. **Cost-Effective and Ready-to-Use:**

- Manufactured at scale, the XCTouchNav is a **cost-effective** solution that is **fully assembled and tested,** making it an ideal addition to any glider cockpit. Its ready-to-use nature ensures minimal setup time, and it is designed to work right out of the box with existing flight systems.

Conclusion:

The XCTouchNav offers a powerful, cost-effective navigation solution for glider pilots, combining modern Android technology with advanced flight features and exceptional display performance. Its seamless integration with XCSoar and other flight instruments, along with its flexible connectivity options, makes it an ideal choice for pilots seeking a reliable and feature-rich navigation system.

2. Features

- The XCTouchNav family boasts an impressive array of features, making it a standout choice for modern glider navigation systems. Key specifications include:

Design and Build

- **Black Conductive Housing:** Provides effective electromagnetic shielding (EMV) for 5.7 and 7 Inch model
- **Power Supply:** Operates directly from a 12V onboard electrical system with polarity protection high power EMV rejection and protection
- **Low Power Consumption:** Optimized based on display size.
- **Durability:** Anti-glare and anti-fingerprint coating for robust and clear operation.

Performance and Display

- **Operating System:** Android 11 and 13 (starting 2025), including Play Store for app versatility.
- **Processor:** 1.8 (latest models 2.0) GHz Quad-Core CPU with 16 GB to 32GB flash memory and 2 or 4 GB RAM.
- **Display:**
 - Multipoint touchscreen for intuitive operation.
 - High-contrast IPS technology with 1200 nits brightness for excellent sunlight readability.

Connectivity

- **Wireless Interfaces:**
 - WiFi (802.11b/g/n) for network connectivity.
 - Bluetooth 4.0 for device pairing.
- **USB Ports:**
 - 80mm model: 2 multichannel USB-A type 2.0 ports.
 - 5.7-inch and 7-inch models: 4 multichannel USB-A type 2.0 ports
 - 5.7 inch USB-C port at the side
 - USB-A ports support device powering (max 1A = 5W).
- **LAN Port:** Available on 5.7-inch
- **IGC-Compatible Serial Interfaces:** Positioned on the rear for seamless integration.
 - 80 mm model: 2 Serial interfaces
 - 5.7 inch: 4 serial interfaces
 - 7 inch V3: 4 serial interfaces, one dedicated for GPS
- **Micro SD Slot:** Supports up to 32 GB memory cards.

Audio and Power

- **Headphone Jack:** 3.5 mm socket for private audio.
- **Stereo Amplifier:** 3W output for enhanced sound.
- **DC Power Input:** 5.1 mm coaxial jack compatible with a 12V onboard supply.

Thermal Management

- **Built-in Fan:** Ensures optimal CPU temperature during extended use.

Software and Features

- **Pre-installed XCSoar:** A powerful and versatile gliding navigation app.
- **Enhanced Performance:** Offers superior speed, connectivity, and user-friendliness compared to other systems on the market.

With its robust performance, extensive connectivity options, and user-friendly design, the XCTouchNav family sets a new standard in glider navigation systems.

3. Overview

3.1. XCTouchNav Integration in the Cockpit Environment

The XCTouchNav is typically integrated into the cockpit environment in the following way:

1. Primary Setup:

The XCTouchNav is most commonly connected to an XCVario via the **serial interface** (this is the recommended connection method). The XCVario, in turn, is connected to a **FLARM** system, providing the necessary data for navigation, variometer readings, and safety features like collision avoidance.

2. Additional Device Connection:

The second port on the **Y-Piece** can be used for connecting an additional device, such as a **FLARM Traffic Viewer**. This allows for enhanced situational awareness by displaying traffic information from the FLARM system directly on the XCTouchNav screen.

This setup ensures that the XCTouchNav works seamlessly with both flight data systems (such as the XCVario and FLARM) while also allowing for additional devices to be integrated into the system for increased functionality and safety. Without XCVario, the Flarm can also be connected directly to the Navi.

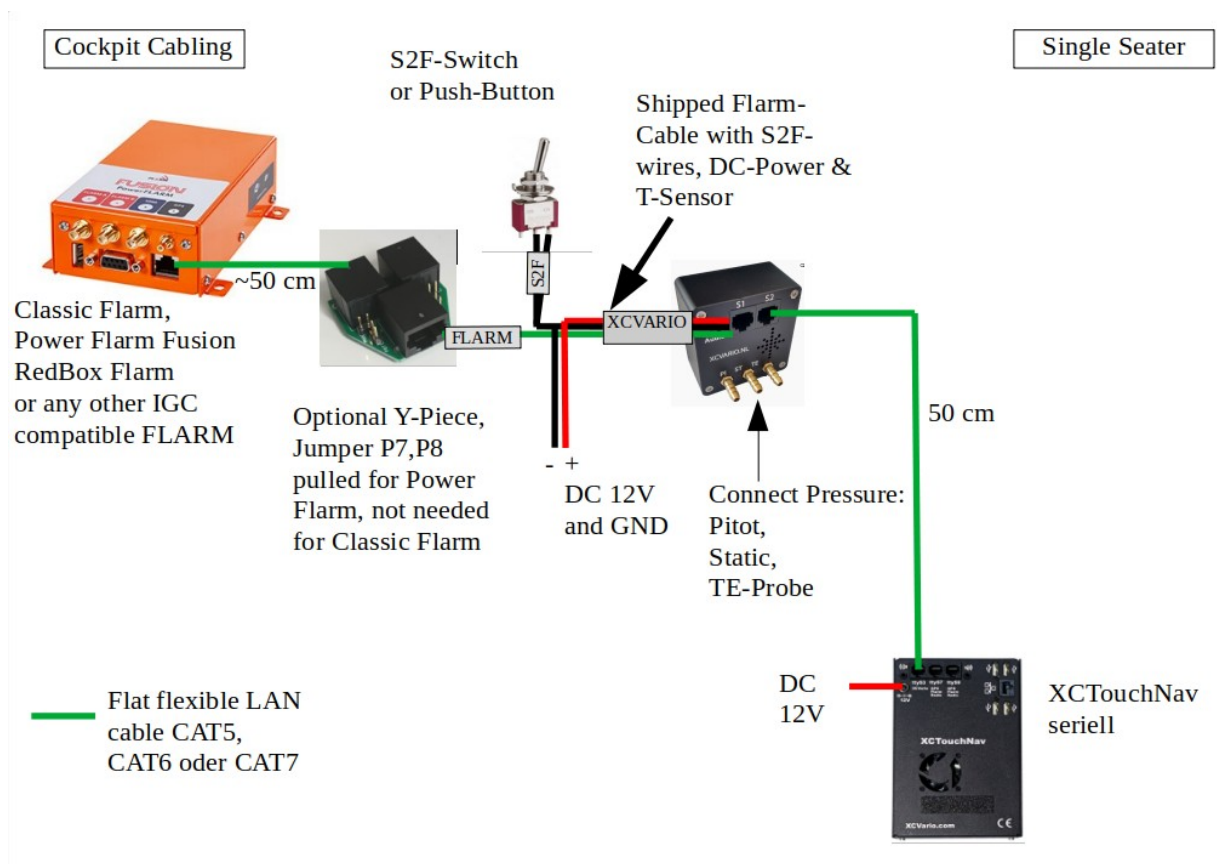

4. Operation

This chapter is based on the XCSoar or OpenSoar manual and provides basic instructions for using XCSoar in a typical local flight. It demonstrates how to use key features, assuming that configuration options have already been set up according to the user's preferences. These instructions serve as a simple, step-by-step guide for flying tasks of varying complexity but are not intended to cover all the features of XCSoar. The system can also be used productively in ways other than those described here. For more detailed information, please refer to the full XCSoar manuals available online at [XCSoar Manual](#).

In addition to XCSoar and OpenVario, **Naviter SeeYou** and **EnRoute apps** are also running on both 5.7 inch and 7 inch displays. They use an external GPS antenna, which the Android firmware exposes as an internal GPS interface.

4.1. Local Flight

In this scenario, the pilot intends to fly locally or undertake a casual cross-country task where navigation to pre-determined waypoints is not required.

4.1.1 Prior to Takeoff

1. **Turn on the device.**
2. Open the **Flight Setup** dialogue and adjust the bugs and ballast as required. Set the maximum forecast temperature. Close the dialogue when done.
3. Open the **Task Edit** dialogue and create a new task by pressing **New**.
4. Select **Touring** as the task type.
5. Once the task is created, move the cursor to the **Add Waypoint** item and press **Enter**. Select the start waypoint from the list (e.g., the home base as the first item) and press **Enter**. Press **Close** or **Escape** to exit.
6. Select **Add Waypoint** again, and enter the same waypoint as the finish point.
7. Now, the task contains a single waypoint to home.

4.1.2 In Flight

- At the appropriate times, manually set the **MacCready** from the menu, task calculator, or variometer. Adjust the bugs/ballast settings as required.
- At any time, the glider can reach home when the altitude difference bar shows a green arrow pointing upwards.
- Optionally, activate **MC Auto** when ready to return home.
- If the MacCready mode is set to **Final Glide** or **Both**, the system will command the optimal speed to return home.

4.1.3 After Landing

- The **Status** dialogue will display the elapsed flight time.
- The **Analysis** dialogue can be used to analyze or review the flight.
- The **IGC Logger Replay** can be used to replay the flight.
- These actions can be performed even after turning the device off and on again.

5. XCSoar



XCSoar is a free and open-source software optimized for Android touch screen systems and comes pre-installed on the XCTouchNav. To launch XCSoar, simply swipe the screen to the right to access the installed apps, then tap the XCSoar icon to start the application.

5.1. Enhancing the Glider Flight Computer

To function as a complete glider flight computer, additional data inputs are required, such as GPS fixes, dynamic pressure, TE (Total Energy) nozzle pressure, and static pressure. These inputs enable precise calculations for optimal speed-to-fly, accurate final glide predictions, and a detailed moving map display.

The **XCVario**, when connected to a FLARM device, provides all the necessary data via an RS232 serial cable (recommended for reliability) or wireless through WiFi or Bluetooth. For users without a FLARM device, a cost-effective GPS module is available in the shop as an alternative.

5.2. Advantages Over Consumer Devices

While smartphones and tablets may offer adequate display brightness, contrast, and touch functionality, they often struggle in high-temperature environments. In a glider cockpit, where temperatures can exceed 40°C even before takeoff, these devices may shut down due to overheating.

The XCTouchNav is specifically designed for aviation environments:

- **Power Supply:** Operates directly from the 12V onboard electrical system without requiring a DC converter. Polarity reversal or EMV is considered and protected.
- **Temperature Resilience:** Tested to function reliably at temperatures up to 70°C, ensuring uninterrupted operation while consumer devices will shut down.
- **Safety:** Unlike devices with internal lithium-polymer (LiPo) batteries, the XCTouchNav eliminates the risk of overheating or internal Lithium-Polymer accumulators catching fire, offering peace of mind during flight.

5.3. Autostart of XCSoar (or other App)

Any app can be started automatically on boot. To configure the boot application, go to **Settings** → **Apps**, then long-press the app you want to set as the new boot application, as shown below.

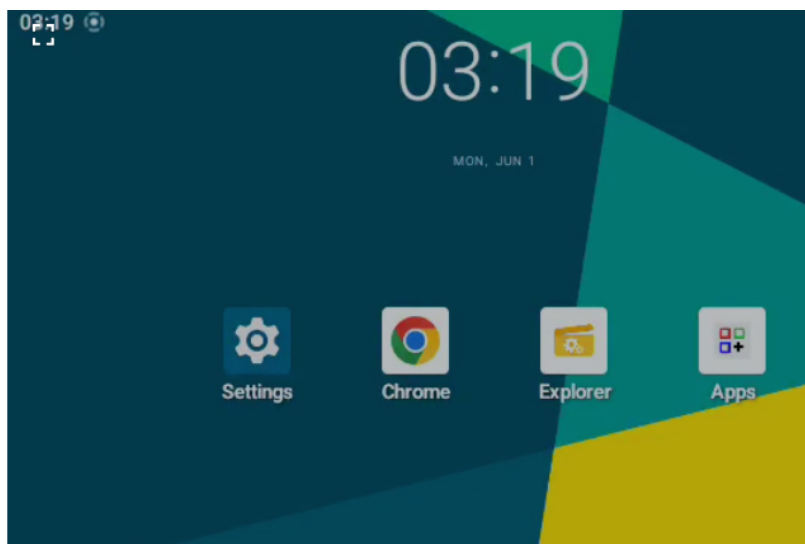

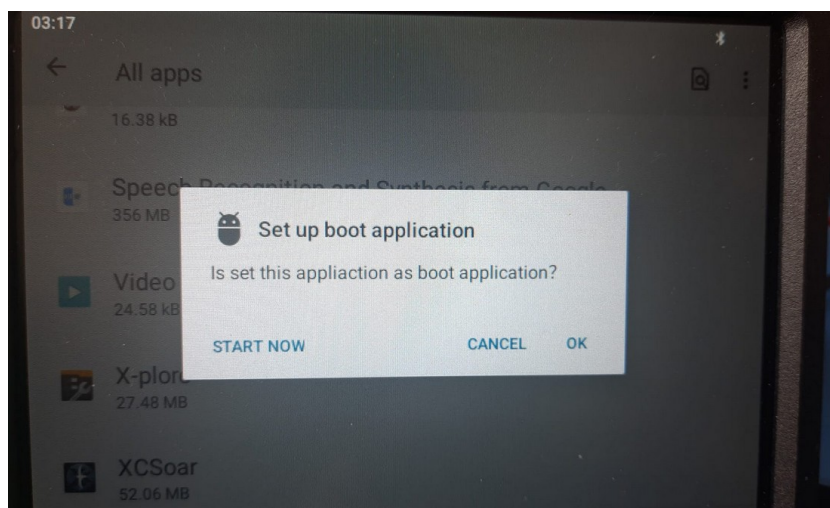
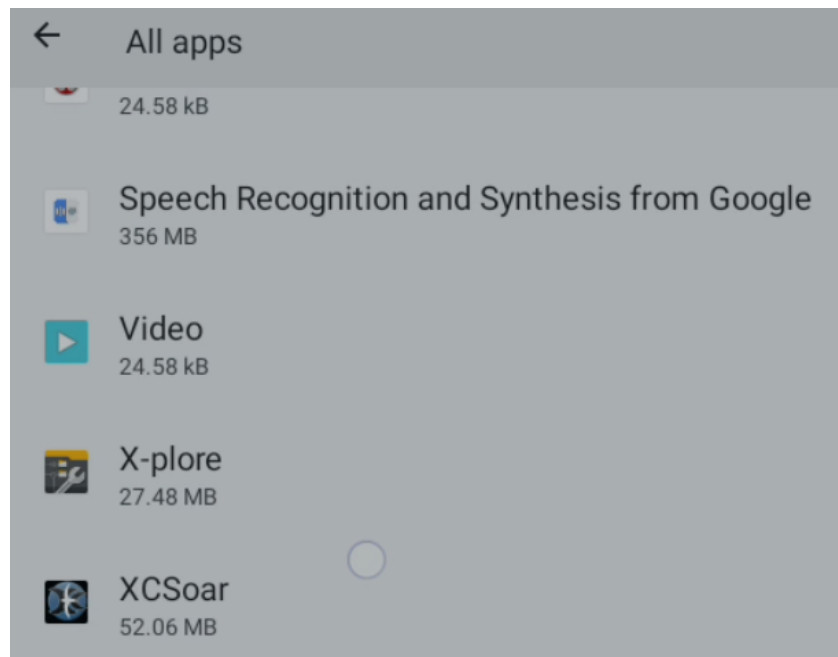
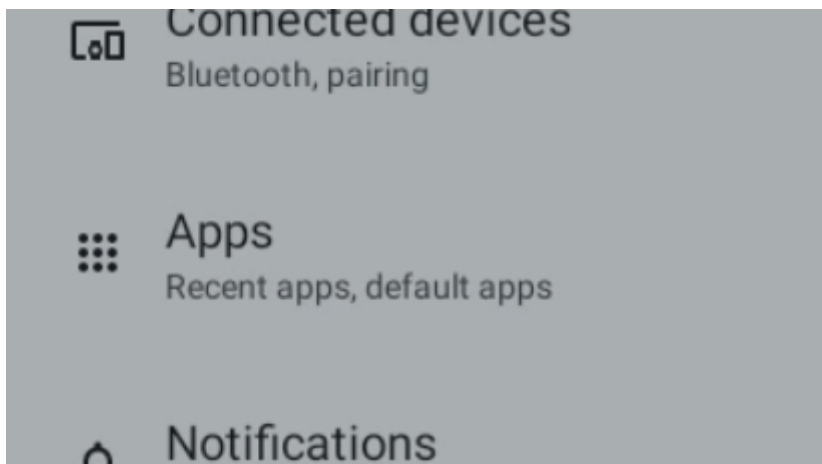

6. Advanced Features and Technology

The XCTouchNav, powered by XCSoar, provides a state-of-the-art glider computer with cutting-edge technology:

- **Hardware:**
 - Quad-core CPU for smooth and responsive performance.
 - Intuitive touchscreen for easy operation.
- **Software Features:**
 - Comprehensive flight planning tools.
 - Internal GPS device with external GPS antenna
 - Final glide calculations.
 - Configurable info boxes for personalized data display.
 - Terrain and airspace visualization, including a side view.
 - Easy setup for topography and landing fields.
 - Thermal assistant for centering thermals.
 - Audio variometer with external speaker support.
 - Speed-to-fly guidance based on MacCready (MC) settings.
 - Assistance for dolphin-style cross-country flying.

Affordable and Reliable Solution

The XCTouchNav offers a robust, safe, and technologically advanced solution at an affordable price, making it an ideal choice for glider pilots. With its pre-installed XCSoar or OpenSoar software and aviation-specific design, it ensures reliable performance and enhances the gliding experience.

7. Bluetooth

To establish a Bluetooth connection with the XCTouchNav, follow these steps:



7.1. Pairing the Device

1. **Enable Bluetooth on XCTouchNav:** Navigate to the Android device setup menu and enable Bluetooth.
2. **Scan for Devices:** Perform a device scan to discover available Bluetooth devices.
3. **Select Your Device:** Look for your target device in the list, such as an XCVario variometer (e.g., "XCVario-5678"), and select it to pair.
4. **Handle Password Requests:**
 - For older devices, if prompted for a password, enter "1234".
 - For newer devices, pairing typically does not require a password.

Configuring XCSoar for Bluetooth Connection

1. Open XCSoar and navigate to **Configuration > NMEA Connection**.
2. Set up a new device (A..F) and:
 - Locate your paired device in the **Connection** field by its Bluetooth ID.
 - Select it, and in the following dialog, specify the desired driver. For current XCVario models, select "XCVario".
 - Ensure the **K6Bt switch** remains in the 'off' position.
3. Confirm your settings by tapping **OK**. XCSoar will establish a connection within a few seconds.

Verifying the Connection

- Once connected, the device will appear as a regular NMEA connection with a status like: "**connected: Baro, Vario, Environment[, FLARM]**".
- To monitor data, navigate to the '**Monitor**' section in XCSoar. Refer to the manufacturer's handbook for detailed information about the data fields and functionality.

Additional Notes

- Multiple Bluetooth devices can be paired and connected to the XCTouchNav simultaneously via the Bluetooth protocol, allowing for versatile setup options.
- Ensure all devices are powered on and in pairing mode during the initial setup for seamless connectivity.

This process ensures reliable communication between XCTouchNav and external devices, enhancing its functionality for glider navigation.

8. Wireless LAN

To set up a wireless LAN (WiFi) connection with the XCTouchNav, for example to connect to a variometer such as the XCVario, follow these steps:



8.1. Enable Wireless LAN on the XCTouchNav

1. Navigate to **Setup > Options > Wireless** on your XCTouchNav.
2. Activate the **Wireless LAN** option to enable WiFi functionality.

Connect to the WiFi Network

1. Open the **WiFi settings** on your XCTouchNav.
2. Look for the network ID of the XCVario, which will match its Bluetooth ID (e.g., **XCVario-5678**).
3. Select the network from the list.

Secure the Connection

- If the network is secured (e.g., HTTPS), enter the password as specified in the manufacturer's handbook for the XCVario or the corresponding device.

Final Steps

Once connected, the XCTouchNav will establish a wireless link with the variometer, enabling data exchange. This setup is ideal for wireless communication without the need for additional cabling. Ensure the XCVario is powered on and within range during the setup process.

For further details about device functionality and data handling, refer to the manufacturer's documentation.

9. Installation



The XCTouchNav device can be installed in the instrument panel using the appropriate cutout. Refer to the technical data section for precise dimensions. The installation process varies slightly depending on the model:

Note: After installation in the corresponding orientation, screen rotation has to be switched off in the Android settings of the device, in order to avoid turning of screen from g-forces:

1. Wipe down screen to lift up Android Quick Setup menu
2. Tap the „Autorotate“ icon to toggle Autorotation status as deactivated (grayed out)



9.1. 5.7-Inch V2 Model

- **Threaded Front Plate:** Equipped with threads in the front plate for direct attachment.
- **Installation Steps:**
 1. Align the device with the panel cutout.
 2. From the backside of the panel, insert screws into the threaded holes on the front plate.
 3. Screw Specifications
 - Use **M2.5x10 screws** for typical installations.
 - For thicker panels, longer screws may be required to ensure a secure fit.

This flexible mounting system ensures compatibility with a wide range of instrument panel configurations, providing a secure and professional installation.

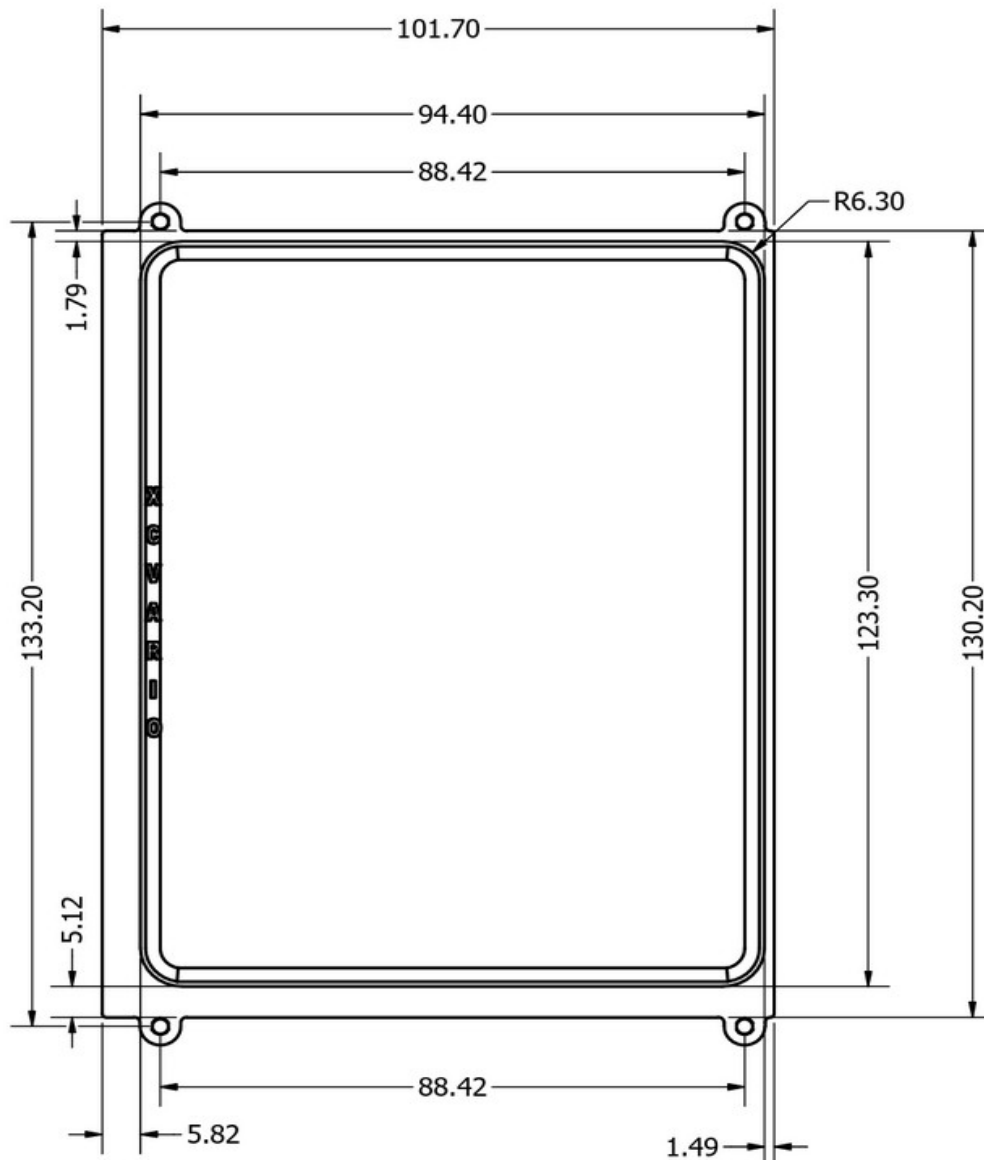

9.2. 7 Inch V3:

- **Fixed Holders:** Comes with holders with best fit for panels with 2-3 mm thickness



9.3. 80 mm:

- **Standard 80mm** Instrument cutout

Note: The 79.6 mm is minimum, a diameter of 80 mm, even more is acceptable as this is covered by the display
There is an own installation manual for the 80mm model that shows the installation of the back and the display.

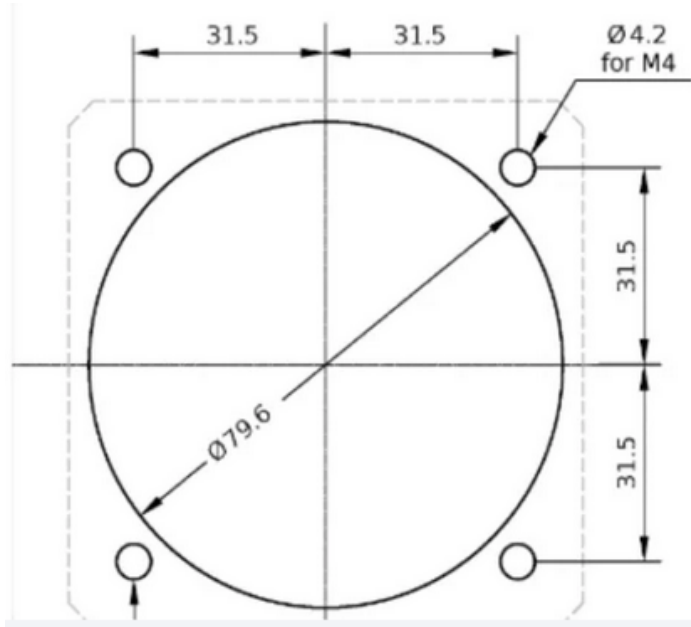

9.4. Electrical connections rear

The electrical connections for the XCTouchNav are consistent across models, with slight variations in the arrangement and available ports. Here's a detailed comparison:

9.4.1. 5.7-Inch

- **Connector Arrangement:**
 - The USB and LAN connectors are positioned at the rear side of the device
- **Available Ports:**
 - **1 x LAN Connector:** e.g. for airspace and topology update's via LAN
 - **3 x Serial Interfaces:** Three serial (tty) interfaces for external device connections.
 - **4x USB Ports:** USB-A ports for peripheral connections, e.g. remote sticks



9.4.2. 7 Inch V3 Models

- **Connector Arrangement:**
 - The USB and Serial connectors are positioned at the rear side of the device
- **Available Ports:**
 - **4 x Serial Interfaces:** Serial (tty) interfaces for external device connections.
 - **USB Ports:** Four USB ports for peripheral connections, e.g. remote sticks



9.4.3. 80mm Model

- **Connector Arrangement:**
 - Simplified design without a LAN connector.
- **Available Ports:**
 - **Serial Interfaces:** Two serial (tty) interfaces, similar to the 5.7-inch model.
 - **USB Ports:** Two USB ports, matching the 5.7-inch model.

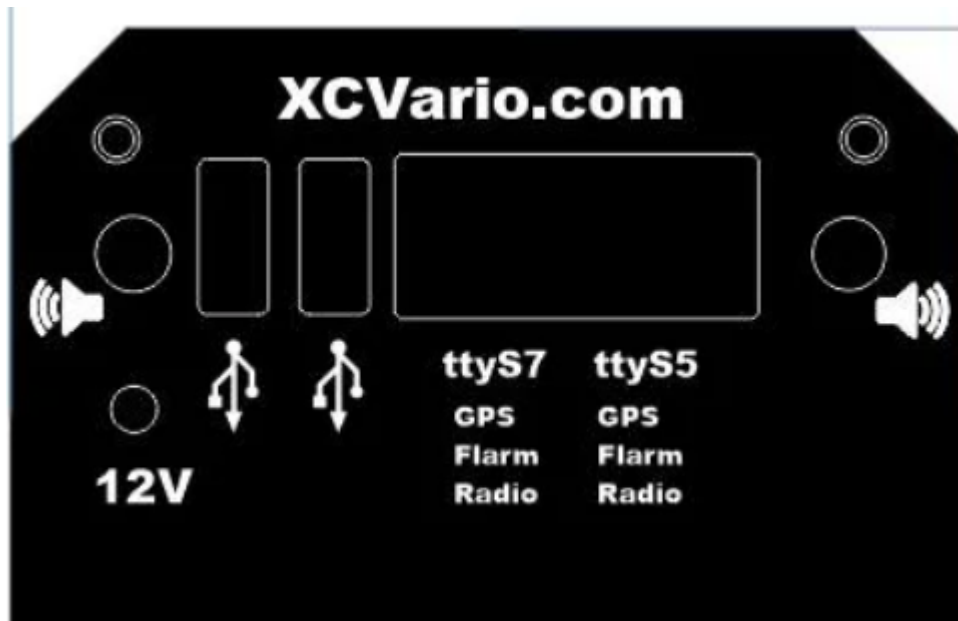

9.5. 12V DC Power



The XCTouchNav device is designed for straightforward integration with the onboard electrical system. Below are the details and recommendations for powering the device:

9.5.1. Power Supply Connection

- **Voltage Range:** The device operates within a voltage range of **10-18 volts**, with **12 volts** being ideal.
- **Cable Requirements:**
 - Use **0.5 mm² copper strands** as a minimum for wiring.
 - **1 mm² copper strands** are recommended for improved durability and reliability.
- **Fuse Recommendations:**
 - While a dedicated fuse for the device is not mandatory in gliders, it is strongly recommended for safety.
 - If connecting the device in parallel with another fused device, ensure the fuse rating is at least **1 ampere**.

Built-in Protections

- **Current Limiting:** A **0.5-ampere self-resetting PTC fuse** protects the device from damage due to external short circuits (e.g., at ttyS7).
- **Polarity Reversal:** The device is protected against incorrect polarity connections.
- **Transient Over-voltage:** Internal protection guards against ESD discharges and induction peaks, such as those caused by engine starts.
- **Startup Precaution:** While the device can tolerate voltage fluctuations during engine starts, it is recommended to keep avionics switched off during such events. If this is unavoidable (e.g., in-flight engine start), the over-voltage protection will help safeguard the device.

Included Power Cable

- The device comes with a **30 cm red/black 12V DC power cable** with **1 mm² copper strands**, already connected for easy installation.

Power Switch Considerations

- The XCTouchNav does not include an internal power switch to save space in the instrument panel.
- **Disconnection Options:**
 - Use an existing avionics main switch in the panel to power off the device.
 - Alternatively, install a dedicated power switch for the device. This is particularly useful for:
 - Preserving battery power.
 - Turning off the device when not in use.

These features and recommendations ensure reliable and safe operation of the XCTouchNav in diverse glider configurations.

9.6. USB

The larger XCTouchNav models are equipped with **four USB 2.0 interfaces**, while the **80mm model** has **two USB 2.0 interfaces**. Each USB port can supply up to **500 mA**, allowing a total of **1.5 A** to be drawn across all USB connections.



For safe operation, the **fuse** used for the XCTouchNav must be rated for at least **2 Amperes** to ensure proper protection and prevent overloading. This ensures that the device can handle the power draw from all connected USB devices without risk of damage or malfunction.

9.7. Audio Out



The XCTouchNav provides two **3.5mm mono jack outputs** for external audio signals, enabling enhanced sound capabilities. Here are the details:

9.7.1. Audio Output

- **Jack Type:** Two **3.5mm mono jacks** are available for external audio output.
- **Speaker Compatibility:**
 - External speakers with a minimum power rating of **3W** can be connected to these jacks.
 - Ensure the speakers are compatible with the mono output for optimal performance.

Use Case

- These outputs are ideal for generating clear and audible sound from the navigation device, such as variometer tones, alerts, or navigation commands, enhancing the usability in noisy cockpit environments.

By connecting external speakers, you can achieve reliable audio performance tailored to your glider setup.

9.8. RJ45 connector's ttyS3, ttyS4, etc

The XCTouchNav features an **IGC standard interface** on the device side, similar to a FLARM system, allowing direct connection to other devices such as the **XCVario** or a PC. Here are the key details:



Abbildung 1: ttyS3 Pinout

9.8.1.IGC Standard Interface

- **Connector Type:** The interface uses an **RJ45 socket**, as shown in the figure above (viewed from the rear).
 - **Pin 1** is located on the **left side** of the connector.
- **Power Considerations:**
 - This interface **provides 12V power** to connected devices except a handful of previous lots, where the left ttyS3 interface does not provide power. All newer devices are shipped with a power split cable, so option for power split still exists using the cable.

9.8.2.Power Supply

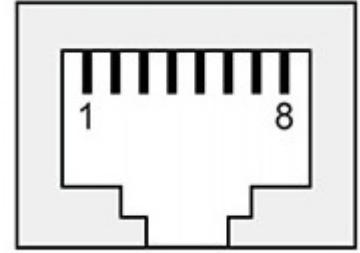
The XCTouchNav is equipped with its own **dedicated power cable** for operation, it should not draw power from the IGC interface as the LAN cable and connectors are not designed for a power usage as the Navi requires.

9.8.3.Power Splitting:

Since the XCTouchNav has its own power source, power splitting should be taken into account when connecting to peers that have their own power source, e.g. Power Flarm, XCVario. From that reason we ship XCTouchNav with a **power split cable 8P4C**.

Conclusion

This interface is designed for data communication and powering of simple low power devices from the Navi. In case the XCTouchNav and connected devices can operate independently in terms of power, connection with a power split cable is recommended. For a high power remote device, or power from another gadget towards the high power drawing Navi, power splitting is mandatory.

Interface ttyS3 and ttyS5 on XCTouchNav-80

| Pin # RJ45 FCC | identifier | direction | Connection XCVario or Remote Device |
|----------------------|--------------|-----------|--|
| 1 | GND | ↔ | GND |
| 2 | GND | ↔ | |
| 3 | RS232 TTL TX | → | Serial RX, remote gadget receives |
| 4 | RS232 TTL RX | ↔ | Serial TX, remote gadget sends |
| 5 | NC | | |
| 6 | NC | | |
| 7 | +12V | 500mA max | Power external device e.g. |
| 8 | +12V | | Classic Flarm |

NC: Not connected

9.8.4. FLARM Connection and Power Supply

The XCTouchNav can connect to **FLARM** devices with an **IGC compatible serial interface**. Here are the details:

- **Power Supply:** The XCTouchNav can **power the FLARM** via a **1:1 cable**. The device can deliver a maximum of **0.5 Amperes** of current to power the FLARM.
- **Flight Declaration and Download:** By connecting the FLARM to the XCTouchNav, you can easily perform tasks like **flight declaration** and **flight download** using navigation applications such as **XCSoar**.

This setup allows for seamless integration with FLARM, providing both data and power through the same connection, while also ensuring flexibility for users who may want to use an external power supply for their FLARM device, e.g. a classic Flarm that does not have a separate power input.

9.9. KRT2 / ATR 833 / Becker Radio

9.9.1. Radio Connection Setup for XCTouchNav

To connect the XCTouchNav to a **KRT2 radio** (or another radio model supported by the navigation device, such as **XCSoar**), the connection can be made via the **serial interfaces** on the XCTouchNav (e.g., **ttyS5**, **ttyS7**, or **ttyS9**). The baud rate should be set to **9600 baud** for proper communication.

9.9.2. Connection Steps for KRT2 Radio

1. Wiring the Connections:

- **TX to RX and RX to TX:**
 - **XCTouchNav Pin 3 (TX) <-> KRT2 Pin 13 (RX)**
 - **XCTouchNav Pin 4 (RX) <-> KRT2 Pin 2 (TX Remote)**
 - **XCTouchNav Pin 1 (GND) <-> KRT2 Pin 1 (GND)**



From left to right:
 Pin 9: GND Mikrofon
 Pin 10: PTT-L
 Pin 11: PTT-R
 Pin 12: Intercom with Bridge to Gnd
 Pin 13: RX
 Pin 14: Headset
 Pin 15: connected with Pin 8 Batterie+

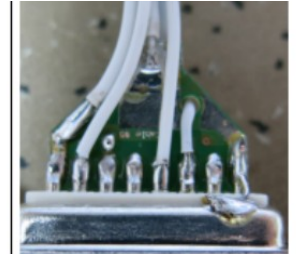

From left to right:
 Pin 8: Batterie plus
 Pin 7: Speaker +
 Pin 6: Mikrofon R
 Pin 5: Ext. NF
 Pin 4: Speaker minus (not GND)
 Pin 3: Mikrofon L
 Pin 2: TX Remote

2. For Older Radios (with LCD display):

- If you're connecting to older radios with an LCD display, a **pull-up resistor** of **27 Kilo-Ohms** may be required between the radio's **TX pin** and **+12V** (battery plus). For example:
 - **KRT2 Pin 2** or **ATR 833 Pin 22**.

This resistor ensures proper communication, as some older radios require this to establish a stable connection.

9.9.3. Connection Setup for ATR833 Radio

For connecting to the **ATR833 radio**, the following pin assignments should be used:

1. XCVario to ATR833:

- **XCV Pin 3 (TX) <-> ATR 833 Pin 9 (Data RX)**
- **XCV Pin 4 (RX) <-> ATR 833 Pin 22 (Data TX)**
- **XCV Pin 1 (GND) <-> ATR 833 Pin 25 (GND)**

Summary

- **Connection Method:** For both KRT2 and ATR833 radios, the connection should be made serially through the XCTouchNav's rear interfaces (**ttyS5**, **ttyS7**, or **ttyS9**).
- **Baud Rate:** Set to **9600 baud** for reliable communication.
- **Wiring:** Always ensure **TX to RX** and **RX to TX** connections are made correctly.
- **Older Radios:** Some older radios may require a pull-up resistor for stable communication.

This setup ensures seamless integration of the XCTouchNav with your radio system, enabling reliable data transmission for navigation and communication purposes.

ATR833-II / P/N 833-II-(Cxxx)-(Cxxx)
 Bedienung und Einbau

f.u.n.k.e.
 AVIONICS GMBH

4.7.2 Stecker-Pinbelegung

| | | | |
|-------------------|----|----|-------------------|
| MICR GND | 14 | 1 | LSP (+) |
| PTT 0 | 15 | 2 | HEAD 0 (+) |
| LSP (-) | 16 | 3 | GND (HEAD 0) |
| PTT 1 | 17 | 4 | EXT NF |
| MICR STD | 18 | 5 | MIC R DYN |
| MICL STD | 19 | 6 | MIC L GND |
| HEAD 1 (+) | 20 | 7 | INTERCOMSWITCH |
| GND (HEAD 1) | 21 | 8 | MIC L DYN |
| DATA TX | 22 | 9 | DATA RX |
| do not connect | 23 | 10 | do not connect |
| +5VDC (TO REMOTE) | 24 | 11 | BATT (+) (14/28V) |
| BATT (-) | 25 | 12 | BATT (+) (14/28V) |
| | | 13 | BATT (-) |

25-poliger Anschlussstecker am ATR833S
 Ansicht von flugzeugseitiger Bestückungsseite

9.9.4.Connection Setup for Becker Radio

Chaper To be done. Becker radio possible with OpenSoar according to the OpenSoar OpenSource project.
Contach info@xcvario.com for details.

9.10.XCVario Setup

All new Navi's have a unique IGC Interface arrangement. Setup XCVario Interface according to the Schema below for a serial connection with the XCTouchNav, e.g. ttyS3



10. Technical specifications

| | | |
|--|----------------|---|
| Operating System | | Android 13 |
| Wireless Interfaces | | WiFi 2.4 GHz Bluetooth 4.2 |
| Serial Interfaces 4800..115200 Baud | 7 Inch V3 | 4x Serial |
| | 5.7 Inch V2 | 4x Serial |
| | 80 mm | 2x Serial |
| USB Interface | 7 Inch V3 | 4 x USB 2.0 accessible on the rear |
| | 5.7 Inch V2 | 4 x USB 2.0 accessible on the rear |
| | 80 mm | 2 x USB 2.0 accessible on the rear |
| Audio Interface 2 x 3 Watts | 7 Inch V3 | 1 x Mono Audio Jack 3.5 mm 1 x built-in Speaker |
| | 5.7 Inch V2 | 1 x Mono Audio Jack 3.5 mm 1 x built-in Speaker |
| | 80 mm | 2 x Mono Audio Jack's 3.5 mm 1 x built-in Speaker |
| Memory | 7 Inch V3 | 16GB Flash, 2GB Ram or 64GB Flash, 4GB |
| | 5.7 Inch V2 | 32GB Flash, 64GB or 128GB, 2 or 4 GB Ram, micro SD card can be added |
| | 80 mm | 16GB Flash, 2GB Ram |
| CPU | | Quad Core 1.8 GHz |
| Display Resolution | 7 Inch V3 | 1024×600 pixel, 1250 nits |
| | 5.7 Inch V2 | 800×600 pixel, 1650 nits |
| | 4 Inch (80 mm) | 480x480 pixel, 1200 nits |
| Power Consumption | 7 Inch V3 | 5 W or 390 mA at 12.8 V |
| | 5.7 Inch V2 | 4 W or 320 mA at 12.8 V |
| | 4 Inch (80 mm) | 2.5 W or 200 mA at 12.8 V |
| Display Cut-Out | 7 Inch V3 | 97 x 172 mm |
| | 5.7 Inch V2 | 86,42 x 123,70 mm |
| | 4 Inch (80 mm) | Standard 80 mm instrument |
| Enclosure Dimension | 7 Inch V3 | 172x97x23 mm, plus screw tabs 5,5 mm |
| | 5.7 Inch V2 | 128,8x101,5x27,50 mm, dito |
| | 4 Inch (80 mm) | 84x84x45 mm |
| Weight | 7 Inch V3 | 440 g |
| | 5.7 Inch V2 | 340 g |
| | 4 Inch (80 mm) | 170 g |

11. Maintenance

The device requires no maintenance. However, it should be stored in a dry environment. Ensure that the relative humidity does not exceed 100% to prevent condensation, which could potentially damage the device.

12. Warranty Policy

The manufacturer offers a **two-year warranty** from the date of purchase, covering the cost of repair and materials. During this period, any components that fail under normal operating conditions will be repaired or replaced free of charge, provided the device is returned to the manufacturer at no cost to them.

The warranty **excludes** damage caused by misuse, abuse, accidents, unauthorized modifications or repairs, incorrect or faulty wiring, over-voltage, or fire.

In accordance with the **German Civil Code**, the device can be returned within **14 days** from the date of purchase. In this case, the device and its accessories must be returned by the buyer to the address from which it was delivered. The buyer is responsible for the return shipping costs.

13. Permit

For each instrument, if the equipment is part of the **Minimum Equipment List (MEL)** or requires approval, it may only be installed if the supplier or manufacturer provides documentation confirming compliance with the relevant specifications for the specific piece of equipment. This documentation is typically provided in the form of the **EASA Form One**, which certifies the proper check and compliance with the required standards.

For all other equipment, including **standard parts**, no such examination or documentation is required. This includes devices such as **final approach computers, flight data recording devices, navigation computers, additional antennas, batteries, cameras, additional pressure probes, mosquito cleaning systems**, and similar items.

This is regulated in detail by **EASA** under **AMC 21.A.303(c) 2**, which states:

“For equipment not part of the minimum equipment list or requiring approval, a corresponding examination and documentation of compliance is not necessary.”

and additionally:

AMC 21.A.303(c) Standard Parts

1. In this context a part is considered as a **‘standard part’** where it is designated as such by the design approval holder responsible for the product, part or appliance, in which the part is intended to be used. In order to be considered a ‘standard part’, all design, manufacturing, inspection data and marking requirements necessary to demonstrate conformity of that part should be in the public domain and published or established as part of officially recognized Standards, or
2. For sailplanes and powered sailplanes, where it is a **non-required instrument** and/or equipment certified under the provision of CS 22.1301(b), if that instrument or equipment, when installed, functioning, functioning improperly or not functioning at all, does not in itself, or by its effect upon the sailplane and its operation, constitute a safety hazard.

‘Required’ in the term ‘non-required’ as used above means required by the applicable certification specifications (CS 22.1303, 22.1305 and 22.1307) or required by the relevant operating regulations and the applicable Rules of the Air or as required by Air Traffic Management (e.g. a transponder in certain controlled airspace).

Examples of equipment which can be considered as standard parts are, variometers, bank/slip indicators ball type, total energy probes, final glide calculators, **navigation computers**, data logger / barograph / turnpoint camera, bug-wipers and anti-collision systems. Equipment which must be approved in accordance to the certification specifications shall comply with the applicable ETSO or equivalent and is not considered a standard part (e.g. oxygen equipment).

This means that **no EASA Form One** is required for the Navi, and it can be installed without the need for additional certification.

Note: After installation, the aircraft's equipment list must be updated. If the addition of the Navi results in a change to the center of gravity due to its mass (as specified in the technical data for the mounting location), and this change cannot be accounted for through a weight and balance calculation, a **weighing** of the aircraft must be conducted. This change must then be approved to ensure compliance with the required safety standards.

14. Limitation of Liability

By purchasing the device, the customer agrees that the manufacturer accepts **no liability** for any direct or indirect damage, claims for damages, or consequential damages of any kind or on any legal basis arising from the use of the device.

This navigation device is intended solely as a **cross-country flight tactical tool** and is **not** part of the required instrumentation for gliders. In case of doubt, it should **not** be used as the primary source for controlling or navigating the aircraft, especially during critical flight phases. The **approved instrumentation** should be used for these purposes. As such, the device does **not require FAA or EASA approval**.

15. CE Declaration of Conformity



DECLARATION OF CONFORMITY

XCVario, owner Dipl. Ing (FH) Eckhard Völlm, Panoramastr. 86/1, D-71665 Vaihingen/Enz, explains that in the normal configuration the device hardware meets the requirements of the CE.

The EMC compatibility corresponds to EN 301 489-3:2002-08 for a Class 3 SRD device (equipment type I).